

# LAGP355

Pneumatic power pivot



L	A	G	P	3	5	5	V	E	0	9	0	B	C	
1	2	3	4	5	6	7	8	9						

<b>1 Series</b> <b>LAG</b> = Power pivot with predeterminate pivot rotation angles	<b>2 Version</b> <b>P</b> = Pneumatic-standard	<b>3 Size</b> <b>355</b> = 350 Nm Ø160 mm
<b>4 Table position</b> <b>V</b> = Vertical 180° <b>O</b> = Horizontal 90° <b>Z</b> = Vertical, mirror of V position <b>P</b> = Horizontal, mirror of O position (Max opening angle 60°)	<b>5 Sensor</b> <b>E</b> = Electronic sensor with M12 swivel connector (DF-U) <b>A</b> = Electronic sensor with M12 swivel connector + electronic sensor for brake condition detection (2x DF-U)	<b>6 Pivot rotation angles</b> <b>120</b> = 120° <b>090</b> = 90° <b>060</b> = 60° <b>045</b> = 45°
<b>7 Brake system</b> <b>B</b> = With brake <b>W</b> = Without brake	<b>8 Valve</b> <b>C</b> = Integrated valve for cycle time optimization	<b>9 Connections</b> <b>D</b> = Right side (sensor right side) <b>F</b> = Front side (in front of the sensor) <b>P</b> = Rear side (same side as sensor)  If not specified, on the left side (sensor left side)

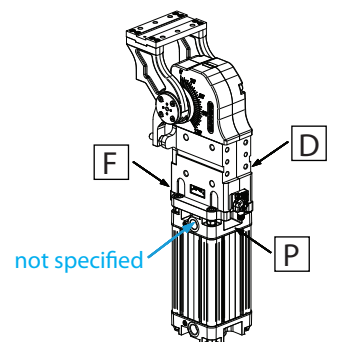

UNIVER SpA recommends that all power pivot applications are validated by UNIVER technical department

## Pneumatic power pivot

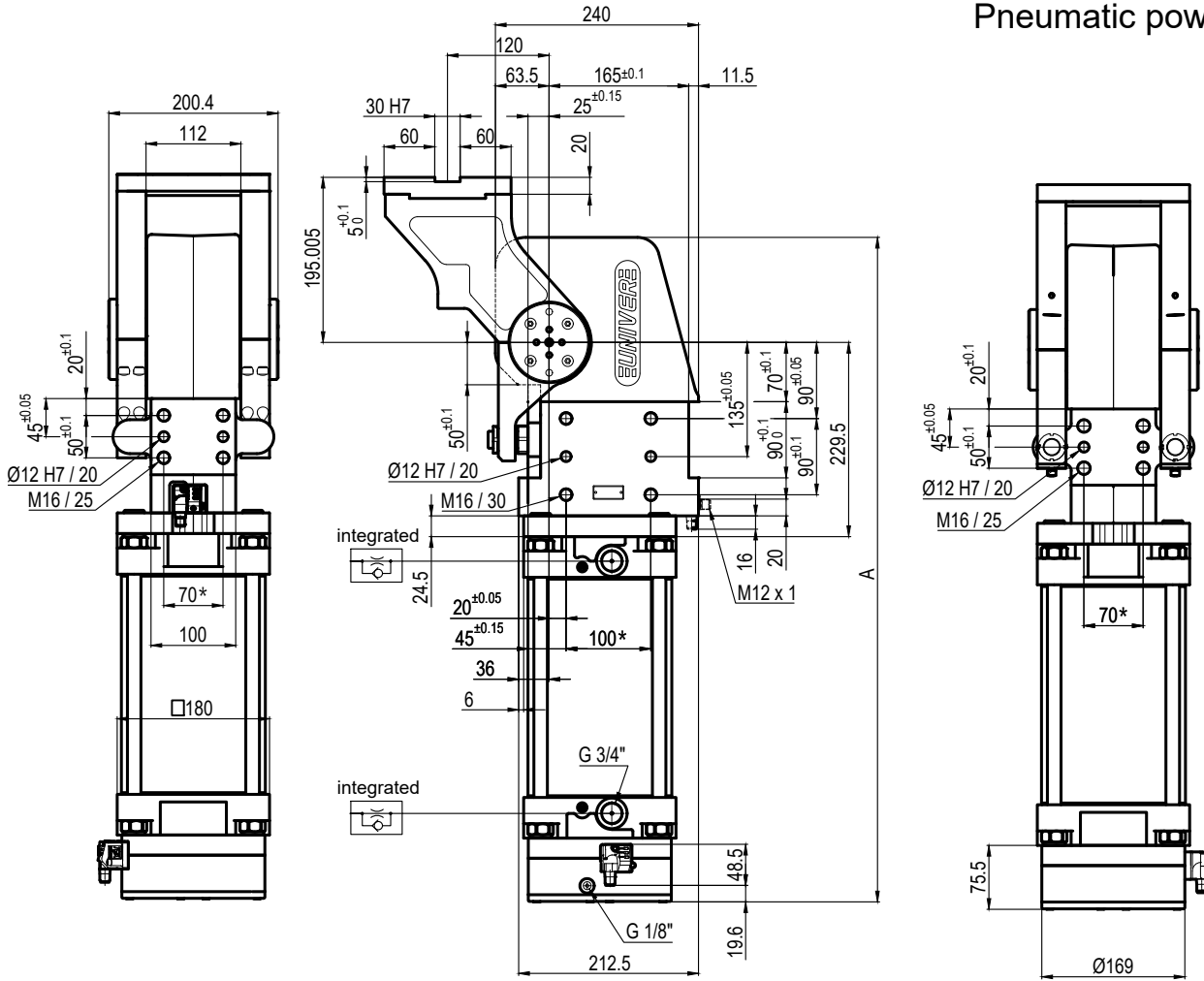

Pivot rotation in degrees	A
45°	691
60°	707
90°	744
120°	784

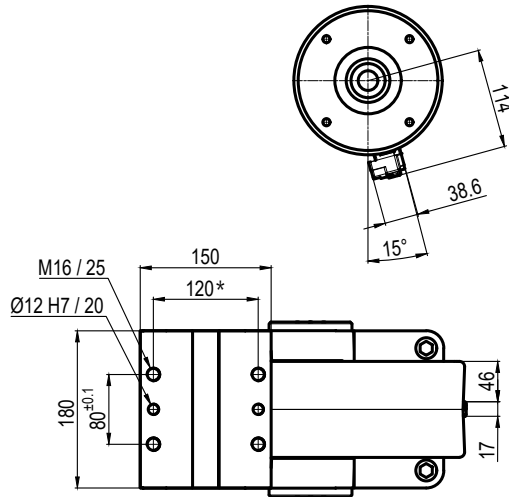

Passive brake:

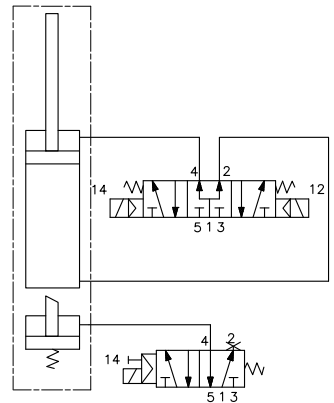

Size	Holding moment	Max. torque at the rotary table 0,55 MPa	Weight
355	8000 Nm	350 Nm	55 Kg

Min./Max. operating pressure: **0,4 / 0,6 MPa**

Operating temperature: **5° ÷ 45° C**

Predetermine pivot rotation in degrees: **45° - 60°**

Electronic sensor with M12 swivel connector that can be orientated at 0° or 90°

Supply voltage: 10÷30 V DC

IP code: **IP 65**

\* : TOLERANCE BETWEEN DOWEL HOLES ± 0.02, TO SCREW HOLES ± 0.1

## Pneumatic power pivot

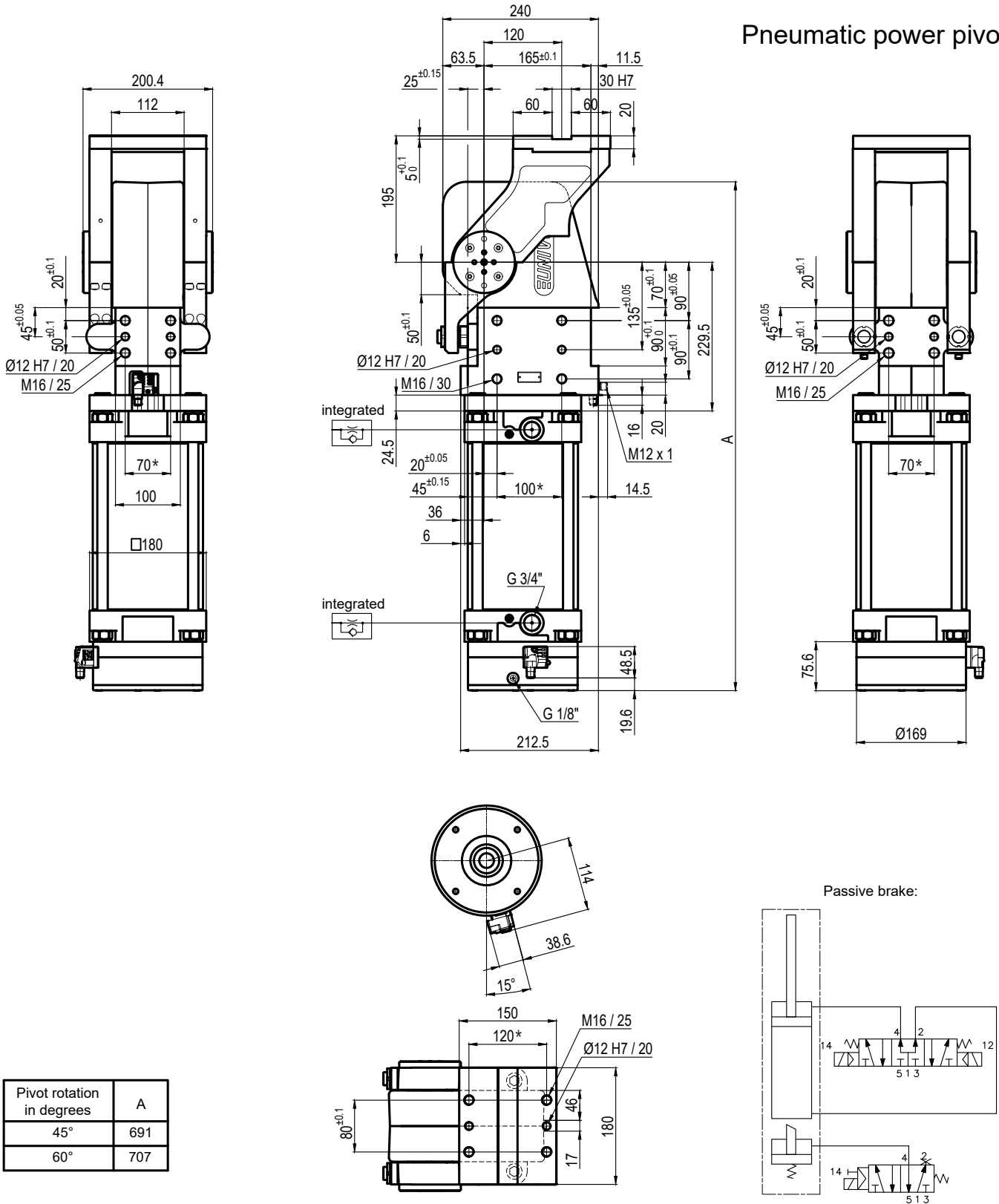

Pivot rotation in degrees	A
45°	691
60°	707

Size	Holding moment	Max. torque at the rotary table 0,55 MPa	Weight
355	8000 Nm	350 Nm	55 Kg

Min./Max. operating pressure: **0,4 / 0,6 MPa**  
 Operating temperature: **5° ÷ 45° C**  
 Predetermine pivot rotation in degrees: **45° - 60°**  
 Electronic sensor with M12 swivel connector that can be orientated at 0° or 90°  
 Supply voltage: 10÷30 V DC  
 IP code: **IP 65**

\* : TOLERANCE BETWEEN DOWEL HOLES ± 0.02, TO SCREW HOLES ± 0.1

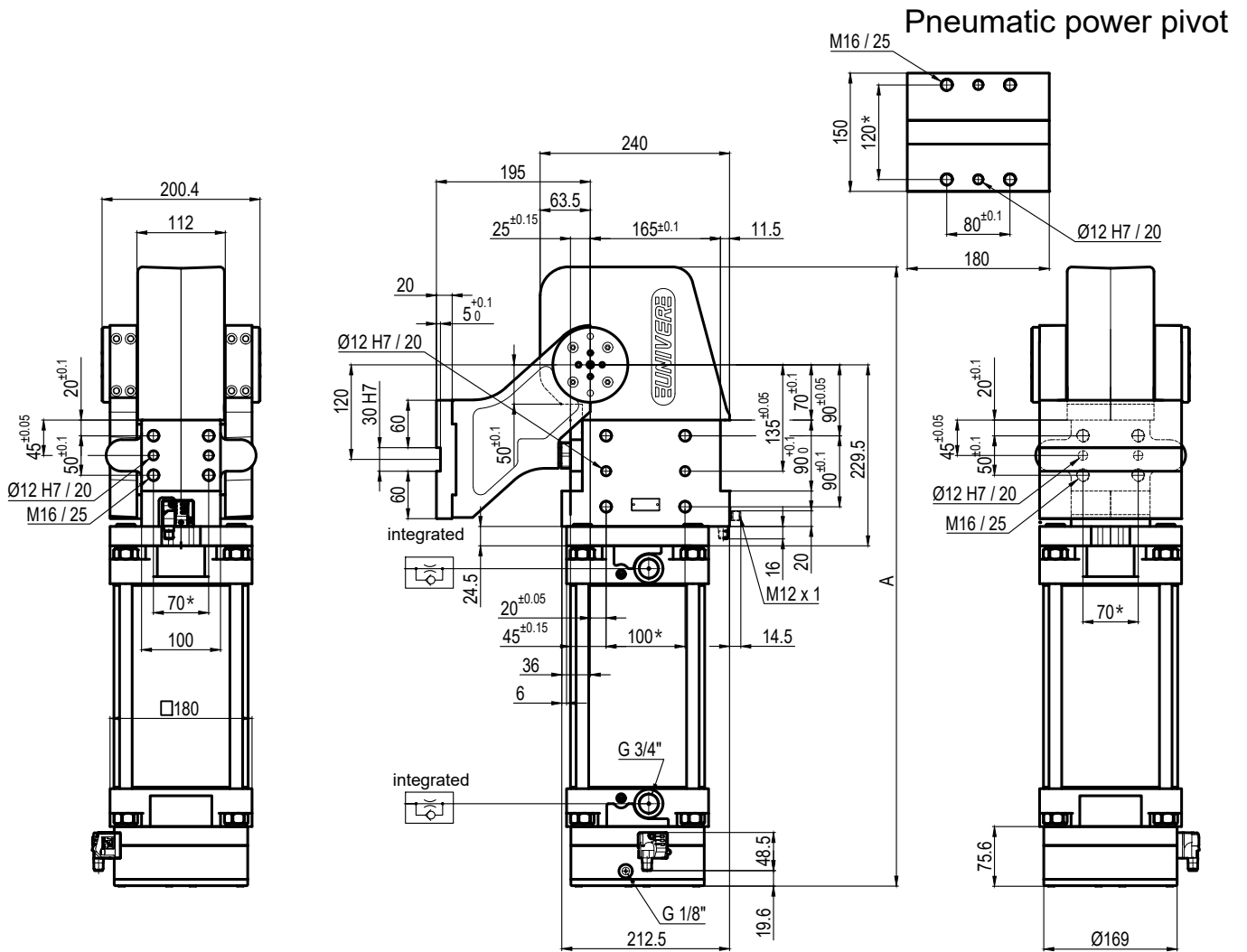

Pivot rotation in degrees	A
45°	691
60°	707
90°	744
120°	784

Size	Holding moment	Max. torque at the rotary table 0,55 MPa	Weight
355	8000 Nm	350 Nm	55 Kg

Min./Max. operating pressure: **0,4 / 0,6 MPa**  
 Operating temperature: **5° ÷ 45° C**  
 Predetermine pivot rotation in degrees: **45° - 60°**  
 Electronic sensor with M12 swivel connector that can be orientated at 0° or 90°  
 Supply voltage: 10÷30 V DC  
 IP code: **IP 65**

\* : TOLERANCE BETWEEN DOWEL HOLES ± 0.02, TO SCREW HOLES ± 0.1

Subject to technical modifications without notice.

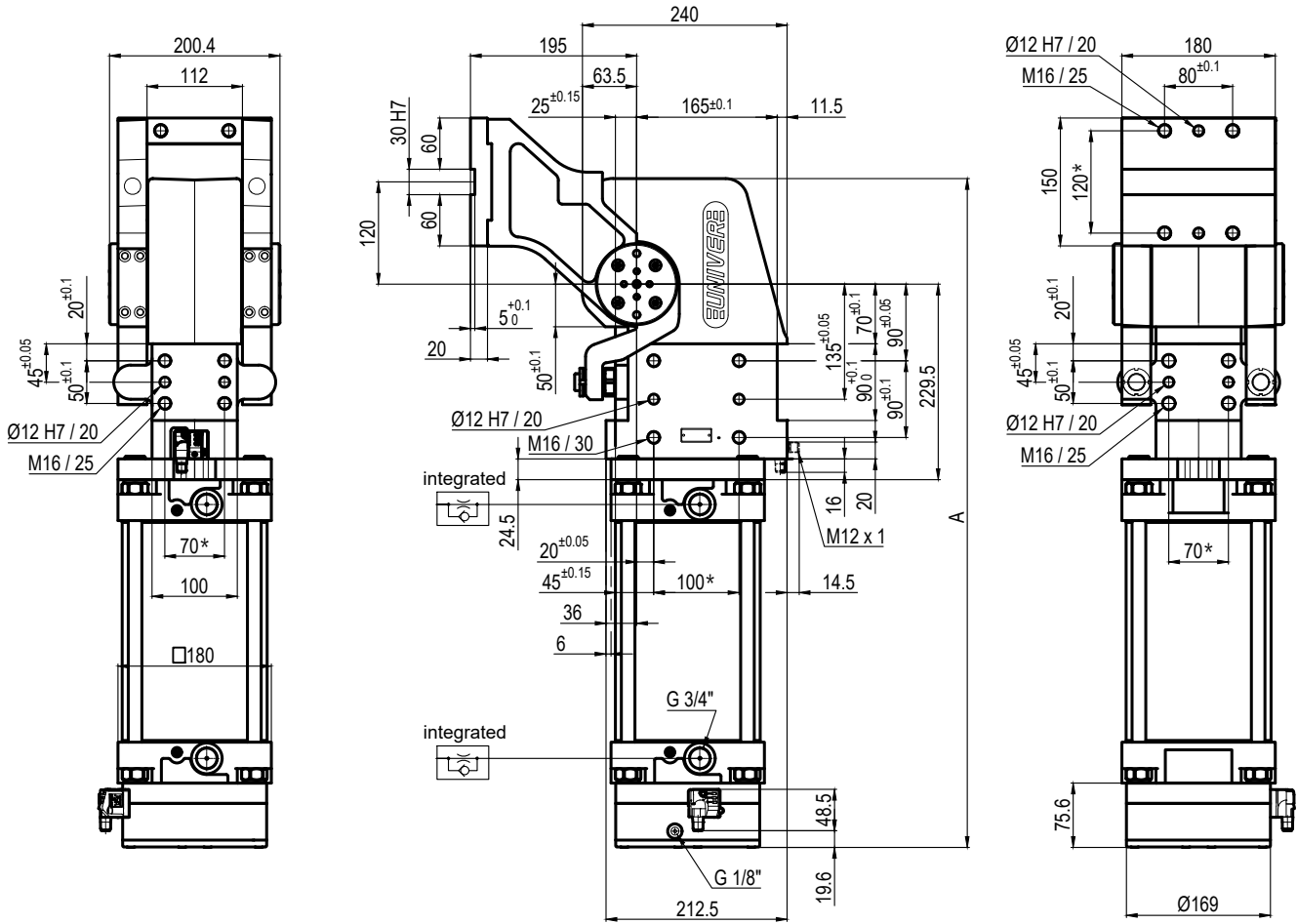

Pivot rotation in degrees	A
45°	691
60°	707
90°	744
120°	784

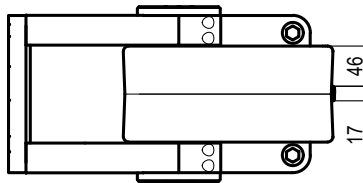
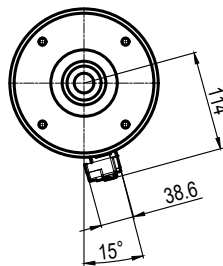

Passive brake:

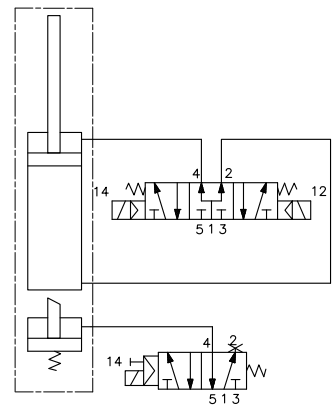

Size	Holding moment	Max. torque at the rotary table 0,55 MPa	Weight
355	8000 Nm	350 Nm	55Kg

Min./Max. operating pressure: **0,4 / 0,6 MPa**  
 Operating temperature: **5° ± 45° C**  
 Predetermine pivot rotation in degrees: **45° - 60° - 90° - 120°**  
 Electronic sensor with M12 swivel connector, from 0° to 90°, in steps of 10°  
 Supply voltage: 10÷30 V DC  
 IP code: **IP 65**

\* : TOLERANCE BETWEEN DOWEL HOLES ± 0.02, BETWEEN SCREW HOLES ± 0.1

Subject to technical modifications without notice.

## Pneumatic power pivot

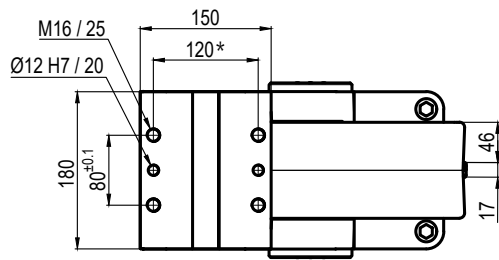
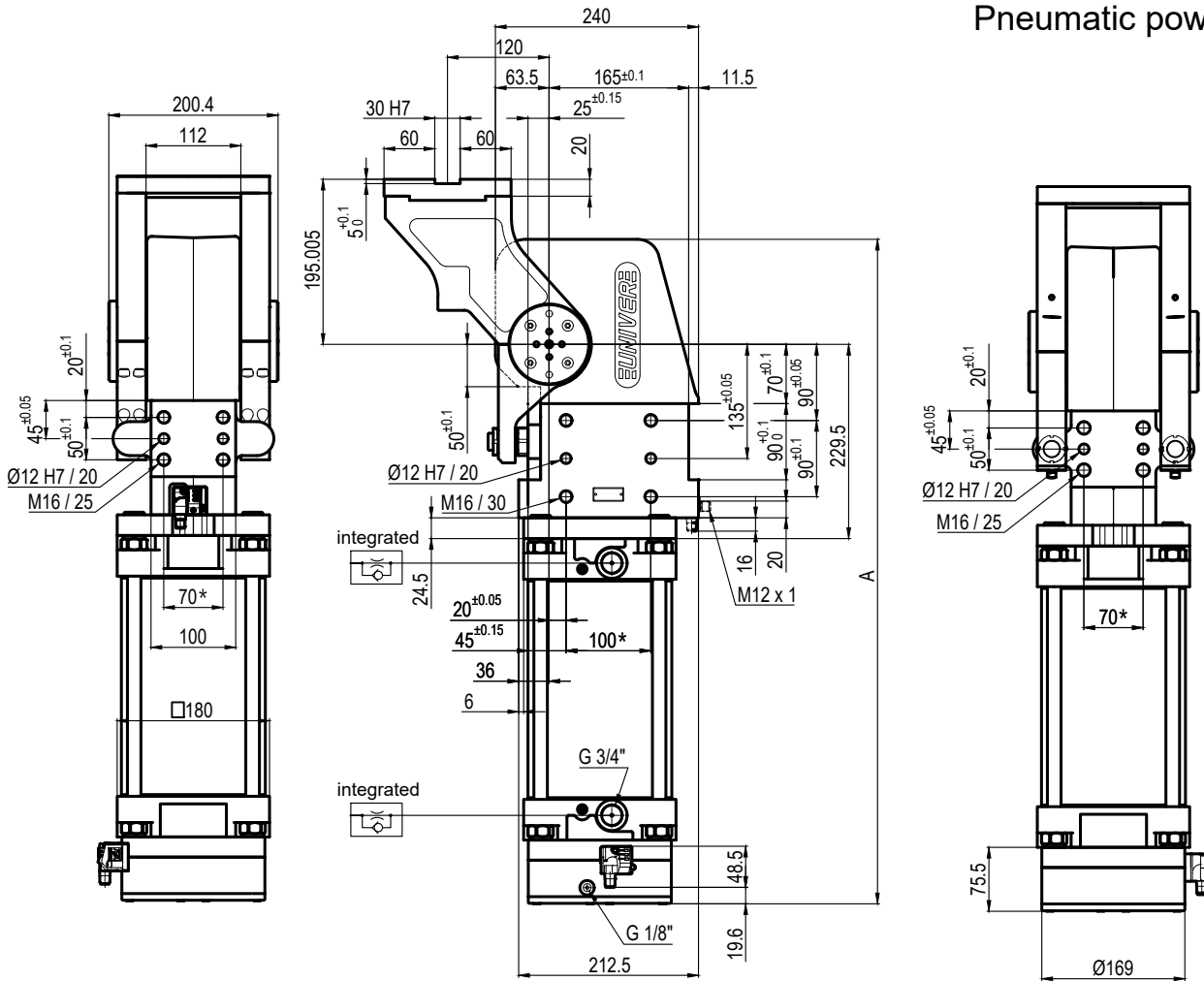

Passive brake:

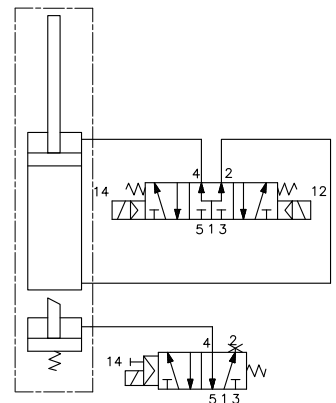

Pivot rotation in degrees	A
45°	691
60°	707
90°	744
120°	784

Size	Holding moment	Max. torque at the rotary table 0,55 MPa	Weight
355	8000 Nm	350 Nm	55 Kg

Min./Max. operating pressure: **0,4 / 0,6 MPa**

Operating temperature: **5° ÷ 45° C**

Predetermine pivot rotation in degrees: **45° - 60°**

Electronic sensor with M12 swivel connector that can be orientated at 0° or 90°

Supply voltage: 10÷30 V DC

IP code: **IP 65**

\* : TOLERANCE BETWEEN DOWEL HOLES ± 0.02, TO SCREW HOLES ± 0.1

## Pneumatic power pivot

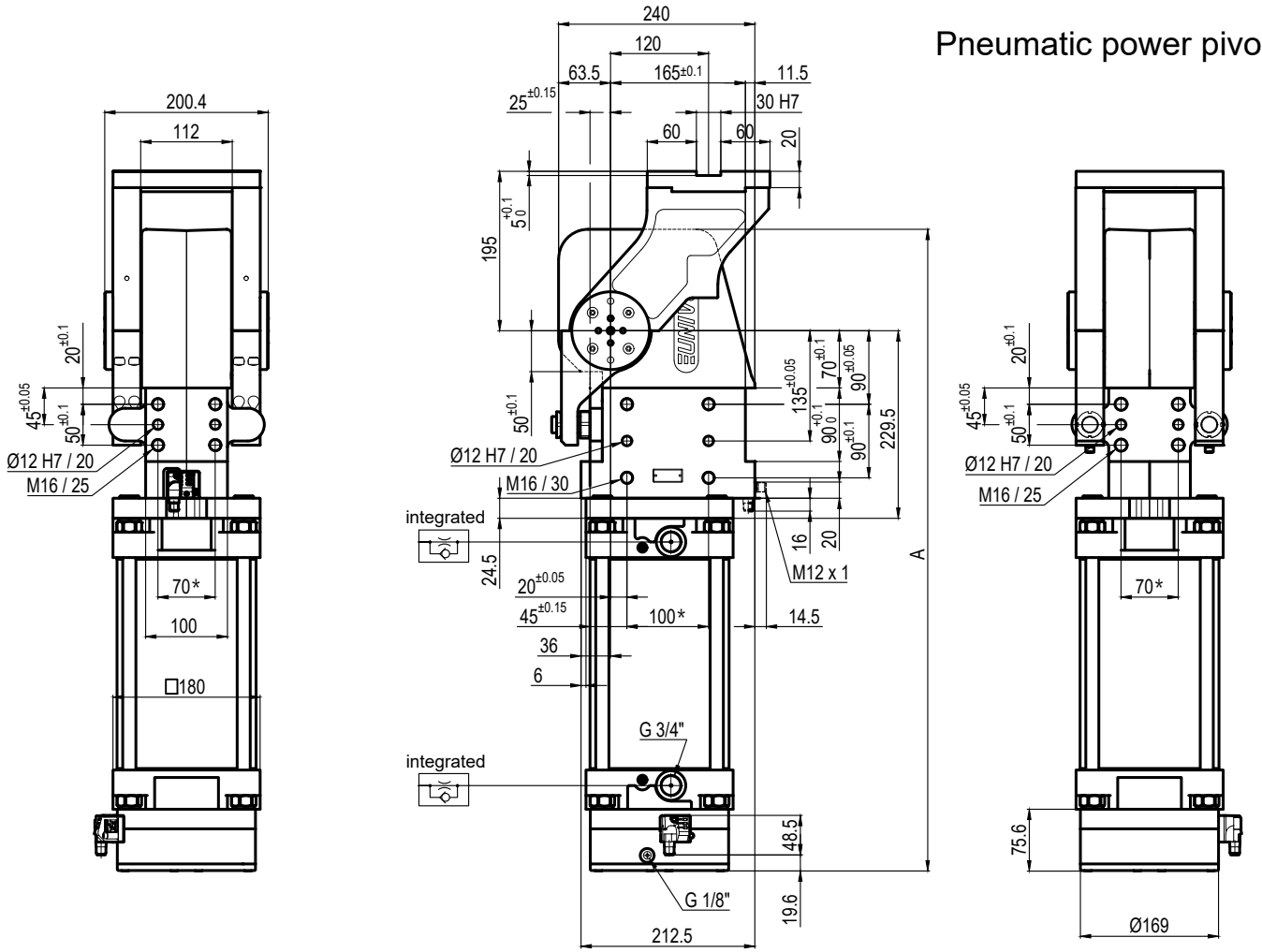

Pivot rotation in degrees	A
45°	691
60°	707

Size	Holding moment	Max. torque at the rotary table 0,55 MPa	Weight
355	8000 Nm	350 Nm	55 Kg

Min./Max. operating pressure: **0,4 / 0,6 MPa**  
 Operating temperature: **5° ÷ 45° C**  
 Predetermine pivot rotation in degrees: **45° - 60°**  
 Electronic sensor with M12 swivel connector that can be orientated at 0° or 90°  
 Supply voltage: 10÷30 V DC  
 IP code: **IP 65**

\* : TOLERANCE BETWEEN DOWEL HOLES ± 0.02, TO SCREW HOLES ± 0.1

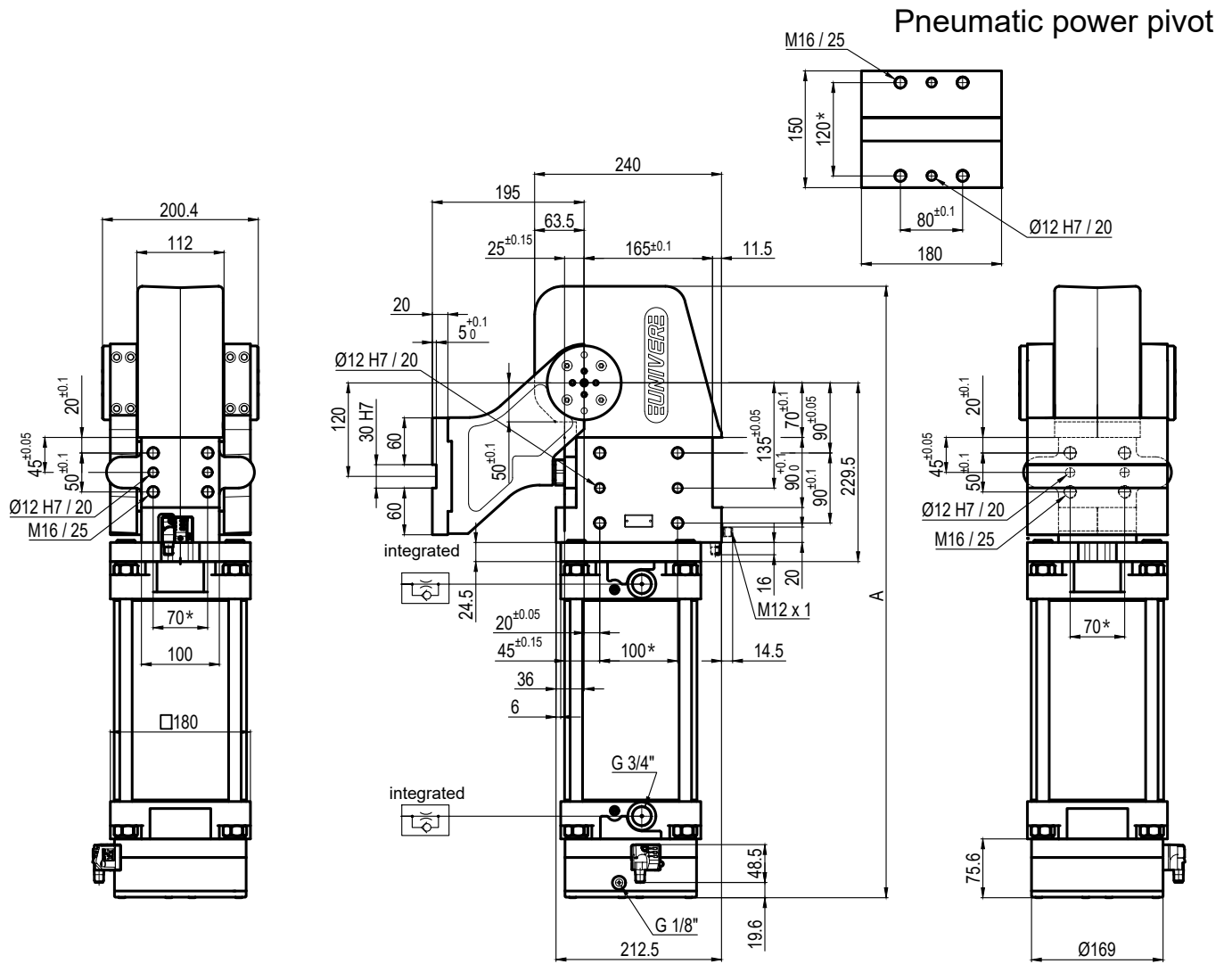

Pivot rotation in degrees	A
45°	691
60°	707
90°	744
120°	784

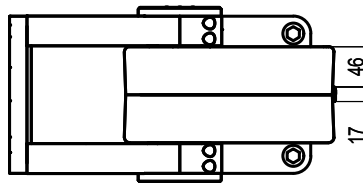

Passive brake

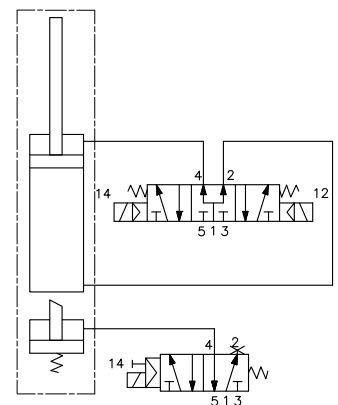

Size	Holding moment	Max. torque at the rotary table 0,55 MPa	Weight
355	8000 Nm	350 Nm	55 Kg

Min./Max. operating pressure: **0,4 / 0,6 MPa**  
 Operating temperature: **5° ÷ 45° C**  
 Predetermine pivot rotation in degrees: **45° - 60°**  
 Electronic sensor with M12 swivel connector that can be orientated at 0° or 90°  
 Supply voltage: 10÷30 V DC  
 IP code: **IP 65**

\* : TOLERANCE BETWEEN DOWEL HOLES ± 0.02, TO SCREW HOLES ± 0.1



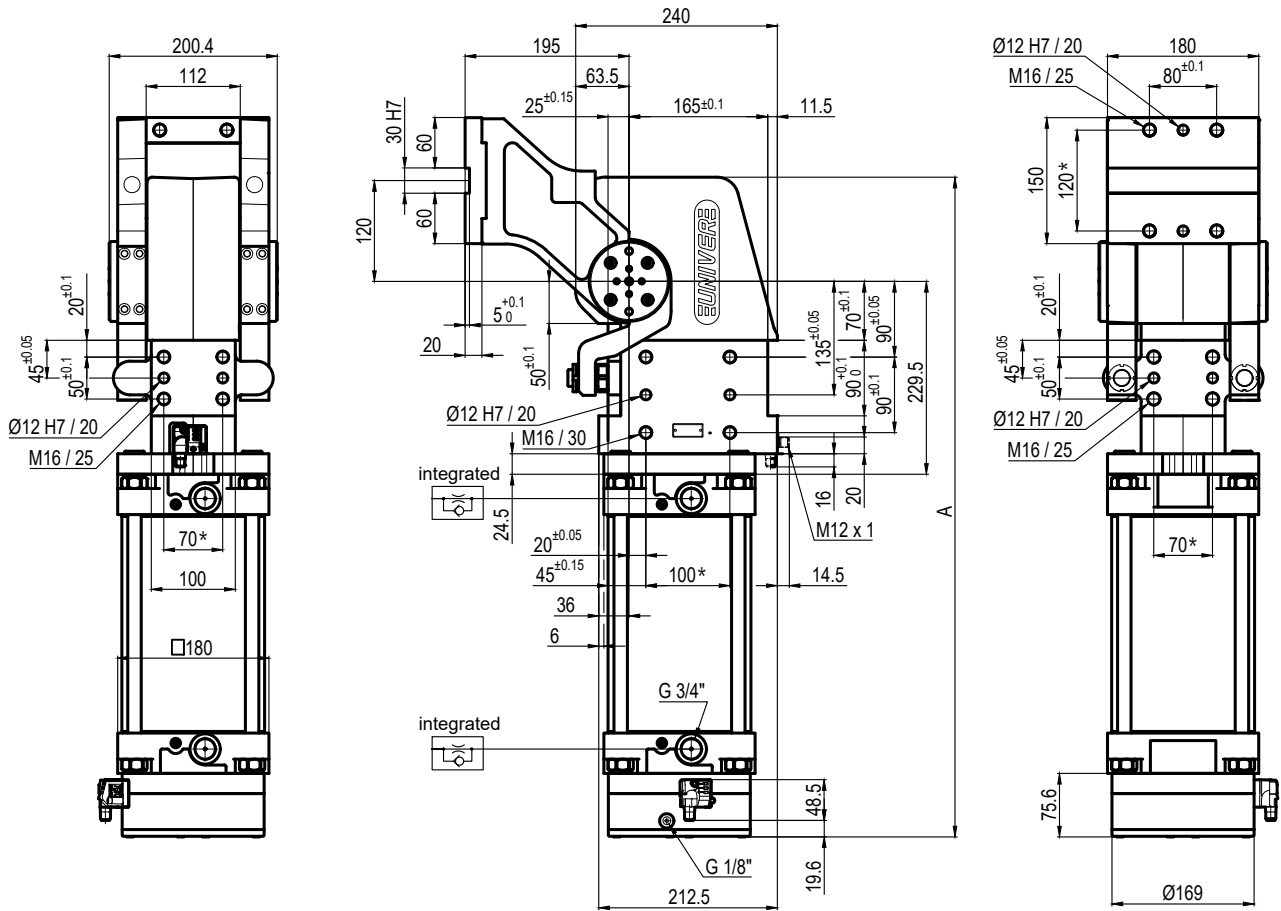

Pivot rotation in degrees	A
45°	691
60°	707
90°	744
120°	784

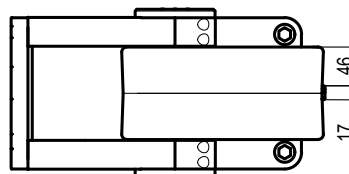

Passive brake:

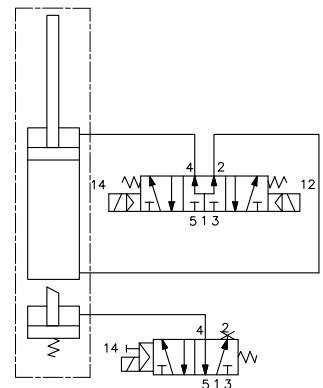

Size	Holding moment	Max. torque at the rotary table 0,55 MPa	Weight
355	8000 Nm	350 Nm	55Kg

Min./Max. operating pressure: **0,4 / 0,6 MPa**  
 Operating temperature: **5° + 45° C**  
 Predetermine pivot rotation in degrees: **45° - 60° - 90° - 120°**  
 Electronic sensor with M12 swivel connector, from 0° to 90°, in steps of 10°  
 Supply voltage: 10+30 V DC  
 IP code: **IP 65**

\* : TOLERANCE BETWEEN DOWEL HOLES ± 0.02, BETWEEN SCREW HOLES ± 0.1

Subject to technical modifications without notice.

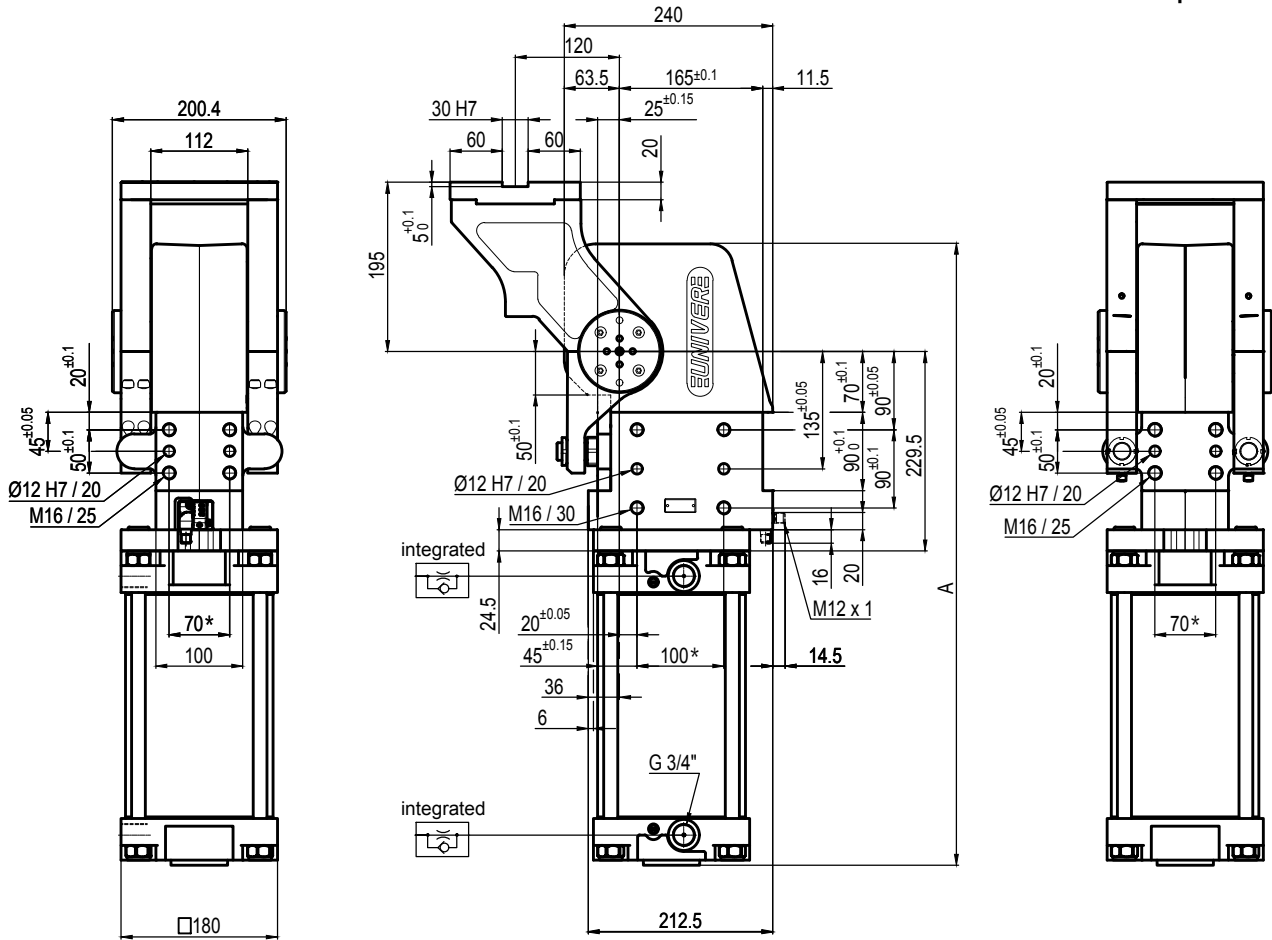

Pivot rotation in degrees	A
45°	622.5
60°	638.5
90°	675.5
120°	715.5

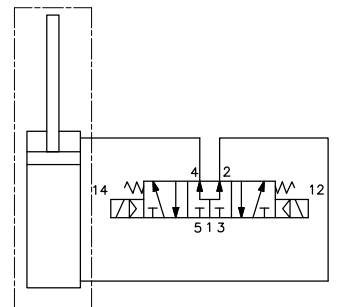
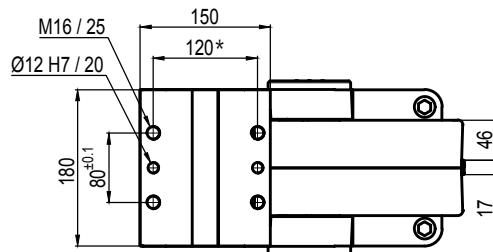

Size	Holding moment	Max. torque at the rotary table 0,55 MPa	Weight
355	8000 Nm	350 Nm	50 Kg

Min./Max. operating pressure: **0,4 / 0,6 MPa**  
 Operating temperature: **5° ÷ 45° C**  
 Predeterminate pivot rotation in degrees: **45° - 60° - 90° - 120°**  
 Electronic sensor with M12 swivel connector that can be orientated at 0° or 90°  
 Supply voltage: 10+30 V DC  
 IP code: **IP 65**

\* : TOLERANCE BETWEEN DOWEL HOLES ± 0.02, TO SCREW HOLES ± 0.1

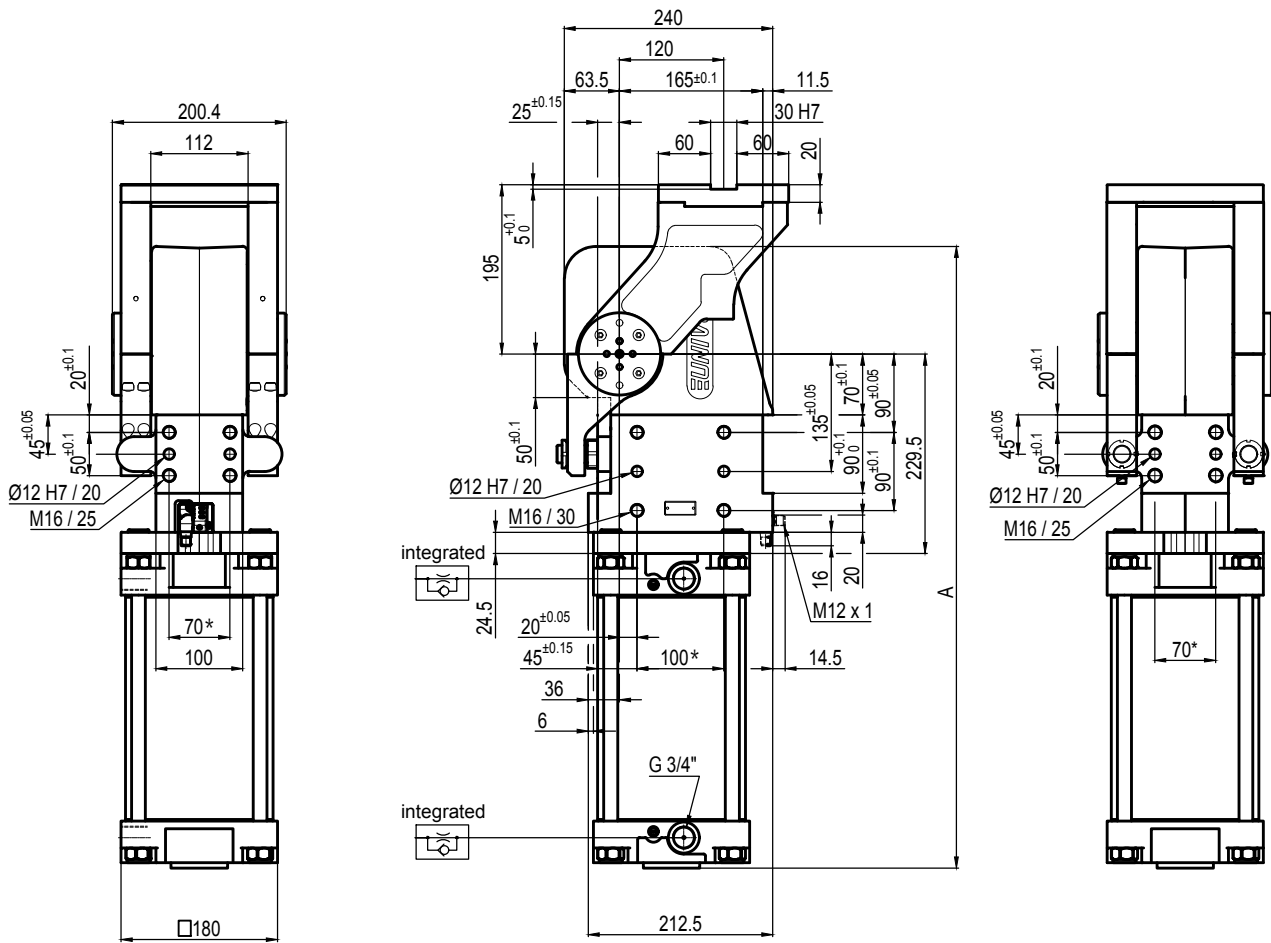

Pivot rotation in degrees	A
45°	622.5
60°	638.5

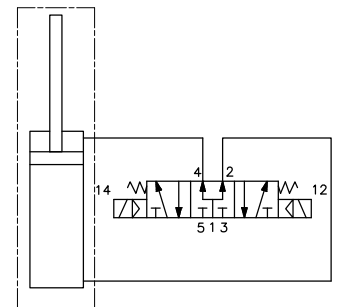
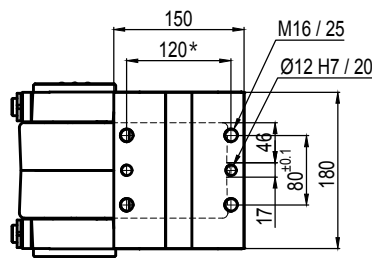

Size	Holding moment	Max. torque at the rotary table 0,55 MPa	Weight
355	8000 Nm	350 Nm	50 Kg

Min./Max. operating pressure: **0,4 / 0,6 MPa**  
 Operating temperature: **5° ÷ 45° C**  
 Predeterminate pivot rotation in degrees: **45° - 60°**  
 Electronic sensor with M12 swivel connector that can be orientated at 0° or 90°  
 Supply voltage: 10+30 V DC  
 IP code: **IP 65**

\* : TOLERANCE BETWEEN DOWEL HOLES ± 0.02, TO SCREW HOLES ± 0.1

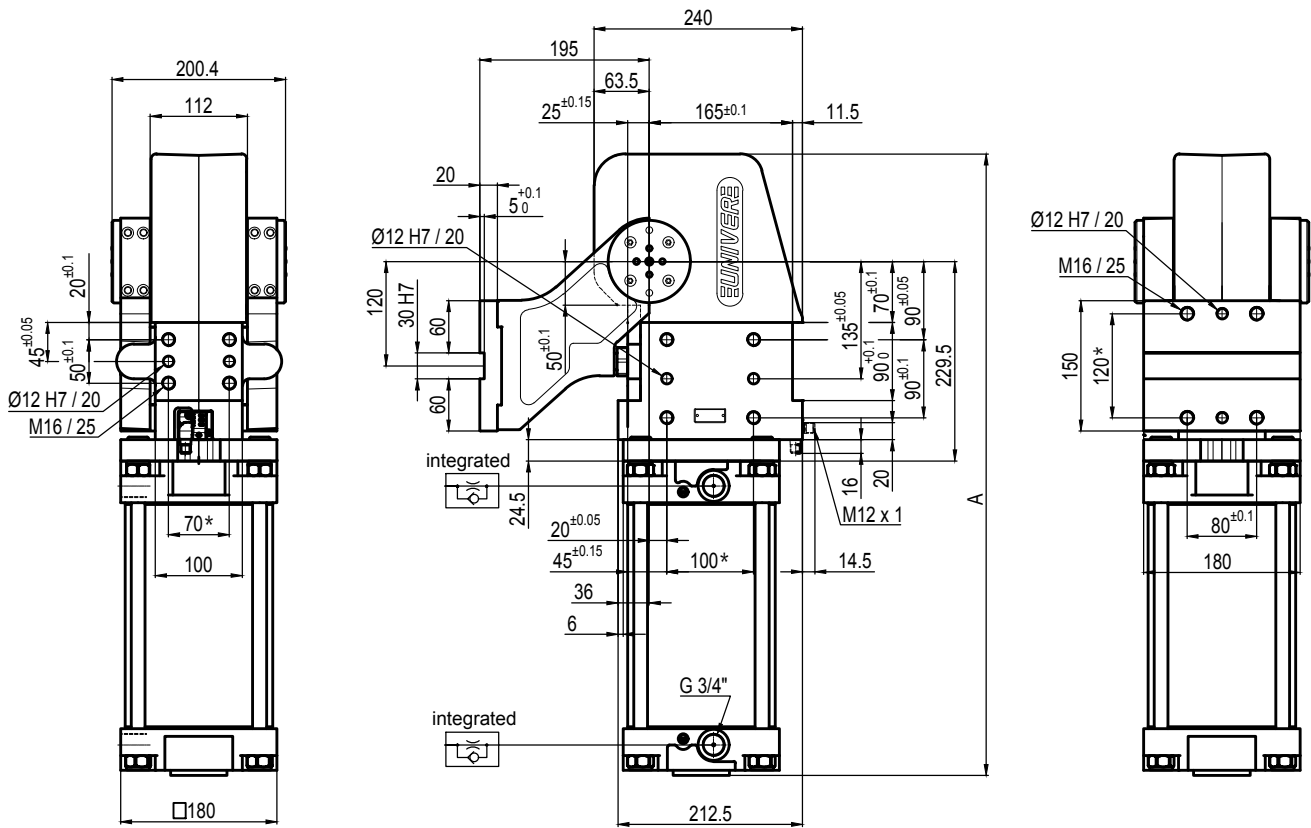

Pivot rotation in degrees	A
45°	622.5
60°	638.5
90°	675.5
120°	715.5

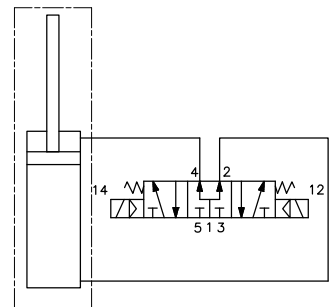
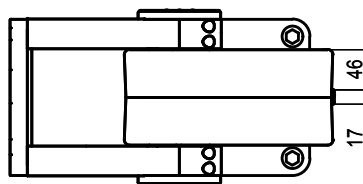

Size	Holding moment	Max. torque at the rotary table 0,55 MPa	Weight
355	8000 Nm	350 Nm	50 Kg

Min./Max. operating pressure: **0,4 / 0,6 MPa**

Operating temperature: **5° ÷ 45° C**

Predetermine pivot rotation in degrees: **45° - 60° - 90° - 120°**

Electronic sensor with M12 swivel connector that can be orientated at 0° or 90°

Supply voltage: 10+30 V DC

IP code: **IP 65**

\* : TOLERANCE BETWEEN DOWEL HOLES ± 0.02, TO SCREW HOLES ± 0.1

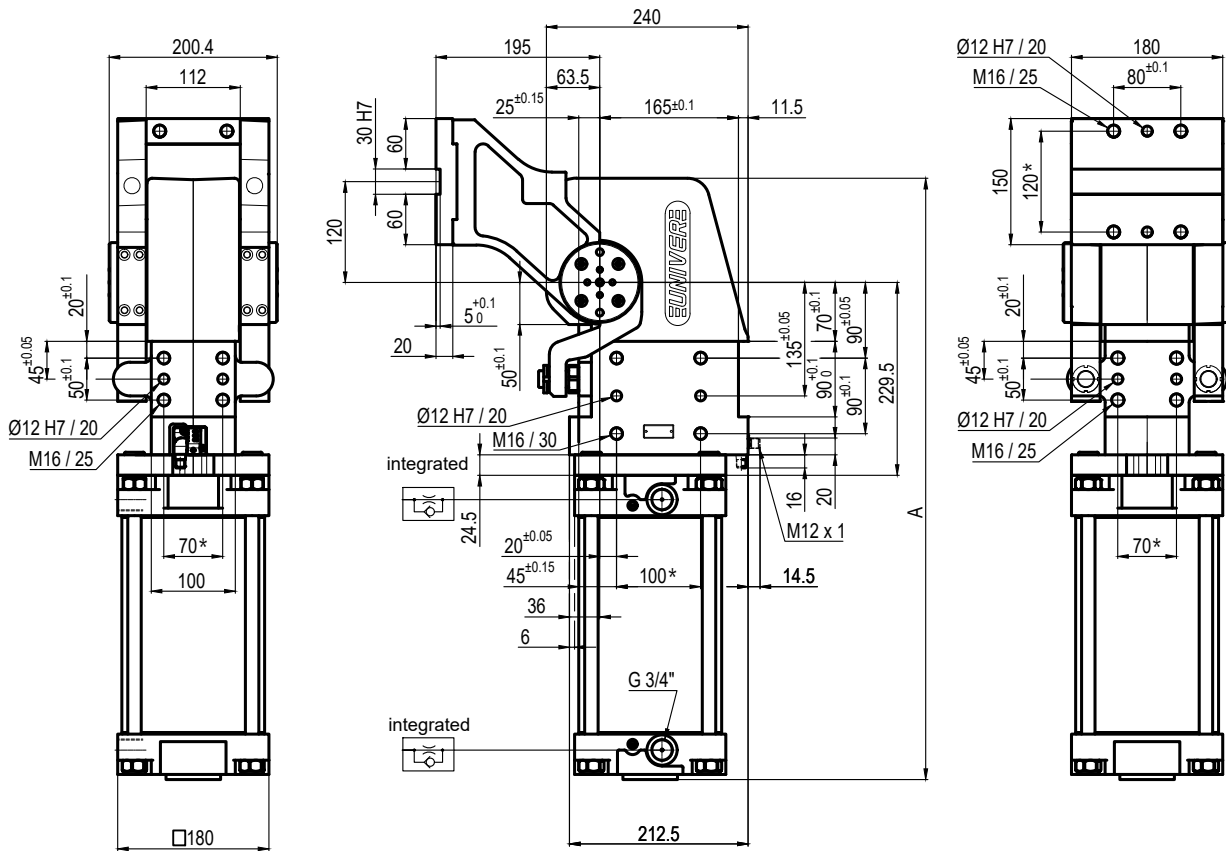

Pivot rotation in degrees	A
45°	622.5
60°	638.5
90°	675.5
120°	715.5

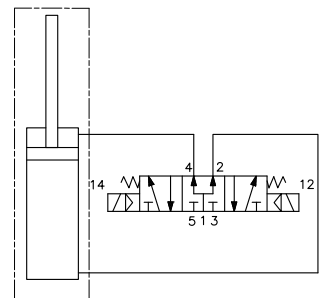
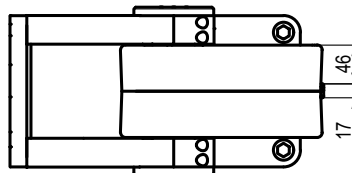

Size	Holding moment	Max. torque at the rotary table 0,55 MPa	Weight
355	8000 Nm	350 Nm	50 Kg

Min./Max. operating pressure: **0,4 / 0,6 MPa**  
 Operating temperature: **5° ± 45° C**  
 Predetermine pivot rotation in degrees: **45° - 60° - 90° - 120°**  
 Electronic sensor with M12 swivel connector that can be orientated at 0° or 90°  
 Supply voltage: 10±30 V DC  
 IP code: **IP 65**

\* : TOLERANCE BETWEEN DOWEL HOLES ± 0.02, BETWEEN SCREW HOLES ± 0.1

Subject to technical modifications without notice.