

□ 19 mm, offset 25 mm

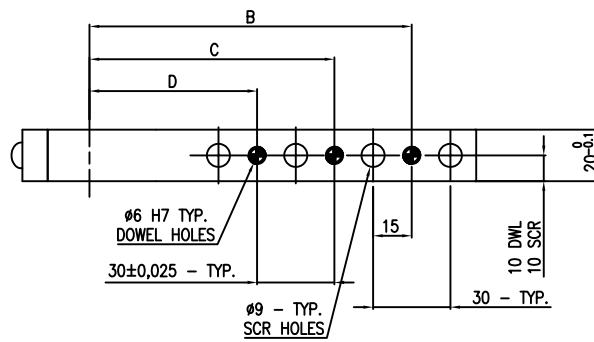

Code	N.A.A.M.S. Code	A	B Dowel	C	D Dowel	Weight Kg	OAL REF	Material
LKPACA246M	ACA246M	90	65			0.56	120	Steel
LKPACA247M	ACA247M	120	95	65		0.66	150	Steel
LKPACA248M	ACA248M	150	125	95	65	0.77	180	Steel

□22 mm, offset 25 mm

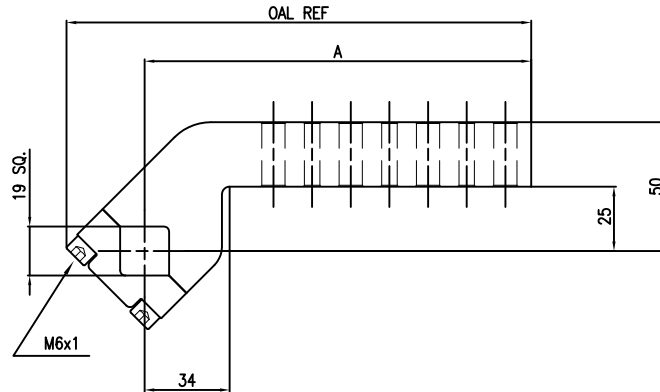
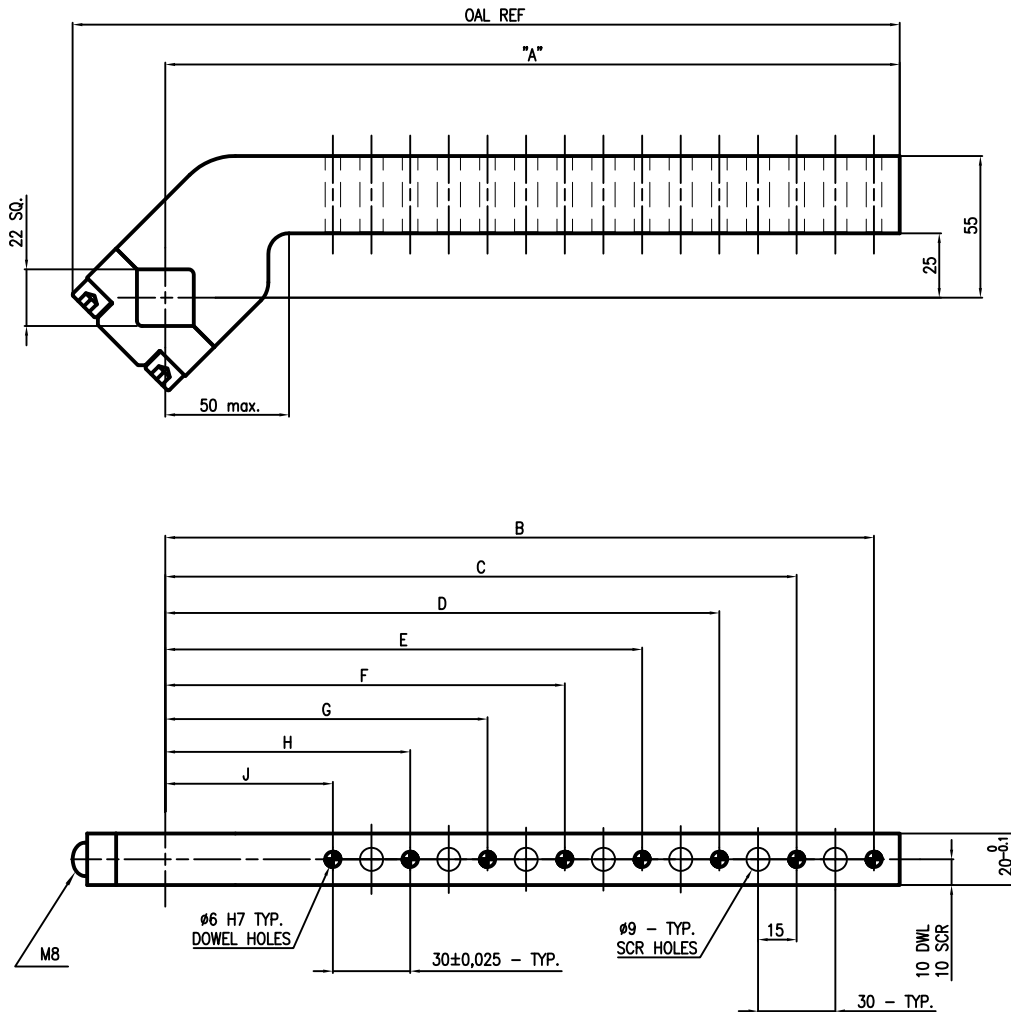

Code	N.A.A.M.S. Code	A	B Dowel	C	D Dowel	E	F Dowel	G	H Dowel	J	Weight Kg	OAL REF	Material
LKPGCA019M	GCA019M	135	125	95	65						0.94	171	Steel
LKPGCA020M	GCA020M	165	155	125	95	65					1.06	201	Steel
LKPGCA021M	GCA021M	195	185	155	125	95	65				1.18	231	Steel
LKPGCA022M	GCA022M	225	215	185	155	125	95	65			1.30	261	Steel
LKPGCA023M	GCA023M	255	245	215	185	155	125	95	65		1.42	291	Steel
LKPGCA024M	GCA024M	285	275	245	215	185	155	125	95	65	1.54	321	Steel

Subject to technical modifications without notice

□30 mm, offset 25 mm

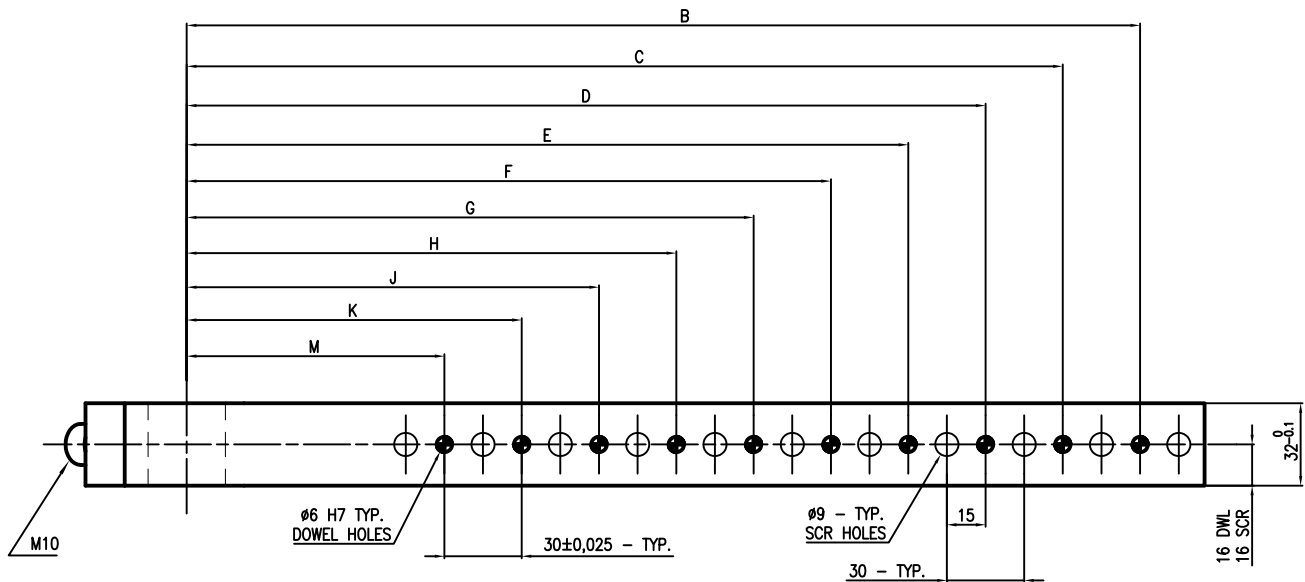
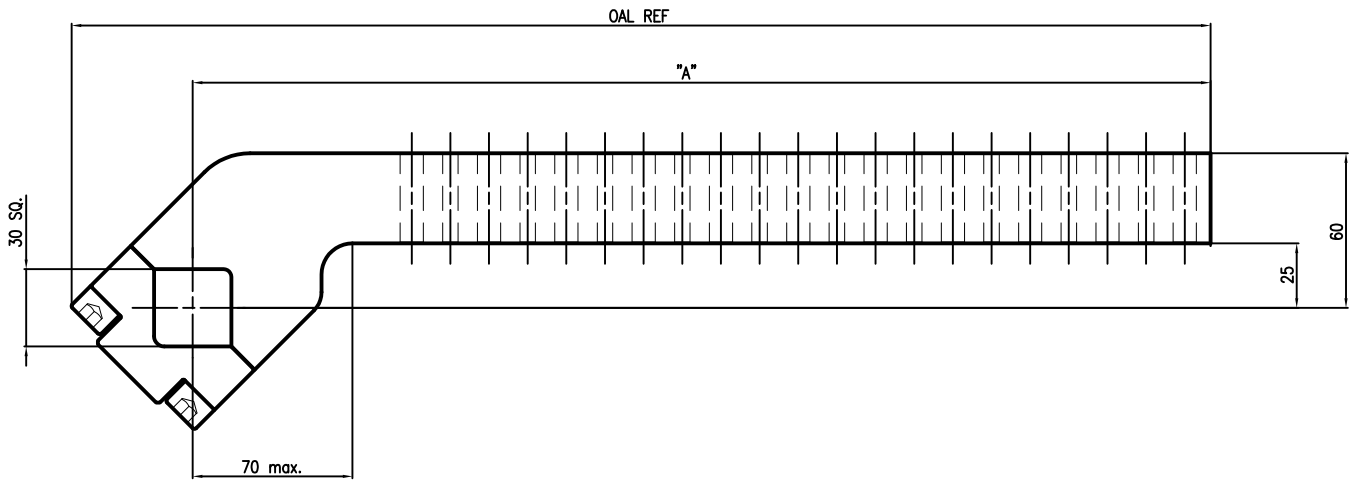

Code	N.A.A.M.S. Code	A	B Dowel	C	D Dowel	E	F Dowel	G	H Dowel	J	K Dowel	M	Weight Kg	OAL REF	Material
LKPGCA130M	GCA0130M	155	130	100									2.17	202	Steel
LKPGCA131M	GCA131M	185	160	130	100								2.42	232	Steel
LKPGCA132M	GCA132M	215	190	160	130	100							2.65	262	Steel
LKPGCA133M	GCA133M	245	220	190	160	130	100						2.88	292	Steel
LKPGCA134M	GCA134M	275	250	220	190	160	130	100					3.12	322	Steel
LKPGCA135M	GCA135M	305	280	250	220	190	160	130	100				3.36	362	Steel
LKPGCA136M	GCA136M	335	310	280	250	220	190	160	130	100			3.60	382	Steel
LKPGCA137M	GCA137M	365	340	310	280	250	220	190	160	130	100		3.84	412	Steel
LKPGCA138M	GCA138M	395	370	340	310	280	250	220	190	160	130	100	4.07	442	Steel

Subject to technical modifications without notice

□19 mm, offset 25 mm for URP/UOP series

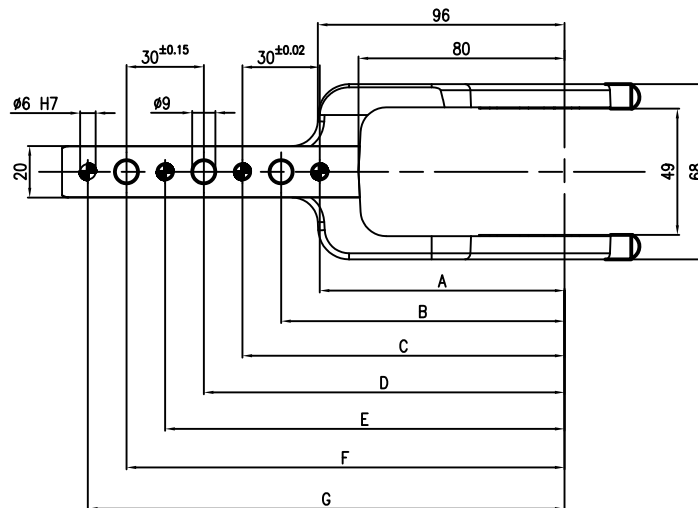
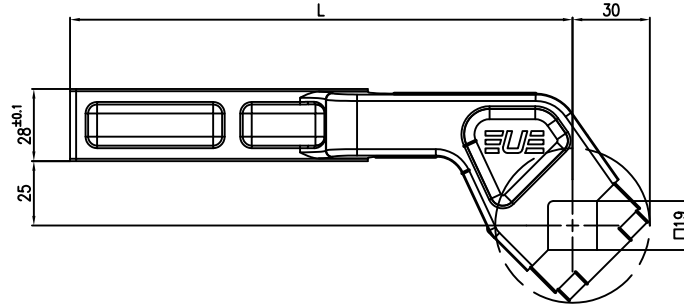

Code	A Dowel	B	C Dowel	D	E Dowel	F	G Dowel	L	OAL REF	Weight Kg	Material
LK019025135WN	95	110	125					135	166	0.30	Aluminium
LK019025165WN	95	110	125	140	155			165	196	0.34	Aluminium
LK019025195WN	95	110	125	140	155	170	185	195	226	0.37	Aluminium

□19 mm, offset 25 mm

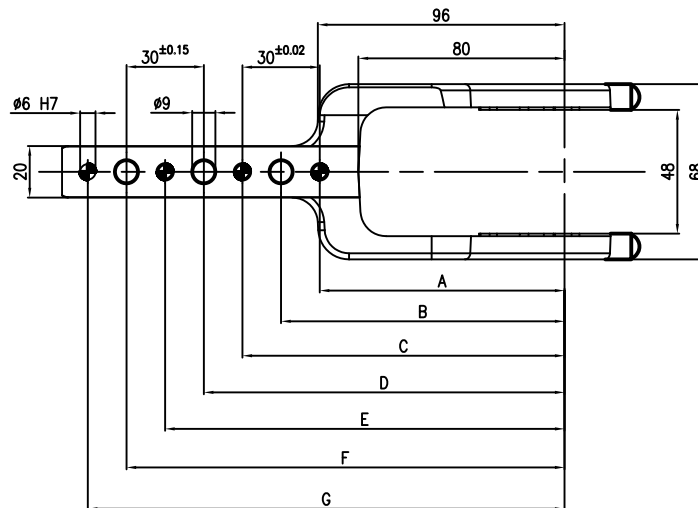
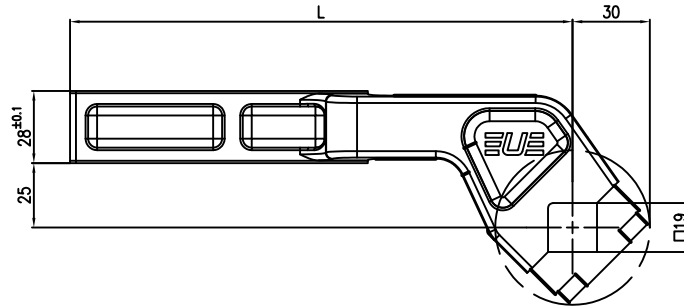

Code	A Dowel	B	C Dowel	D	E Dowel	F	G Dowel	L	OAL REF	Weight Kg	Material
LKP19025135WN	95	110	125					135	166	0.30	Aluminium
LKP19025165WN	95	110	125	140	155			165	196	0.34	Aluminium
LKP19025195WN	95	110	125	140	155	170	185	195	226	0.37	Aluminium

□19 mm, offset 25 mm

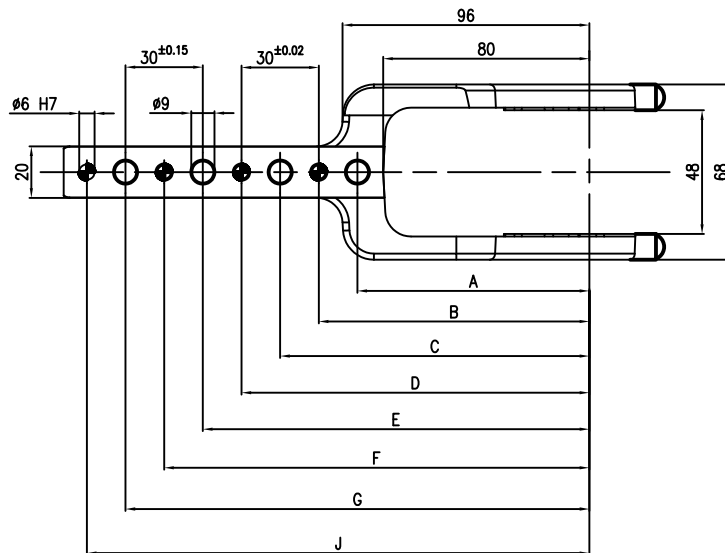
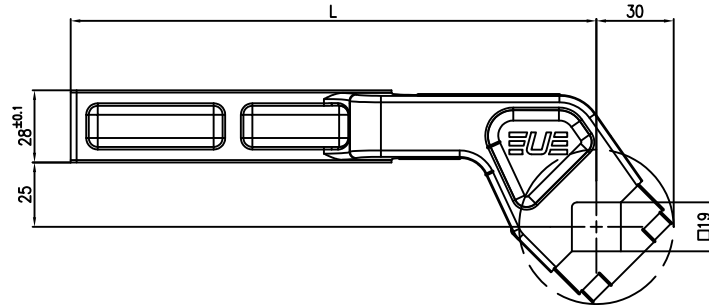

Code	A	B Dowel	C	D Dowel	E	F Dowel	G	J	L	OAL REF	Material
LKP19025144WG	90	105	120	135					144	174	Aluminium
LKP19025204WG	90	105	120	135	150	165	180	195	204	234	Steel

□19 mm, offset 25 mm for URP/UOP series

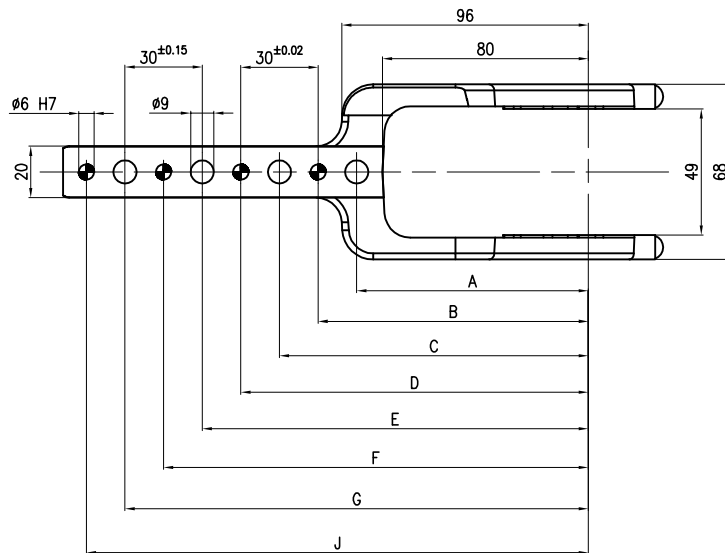
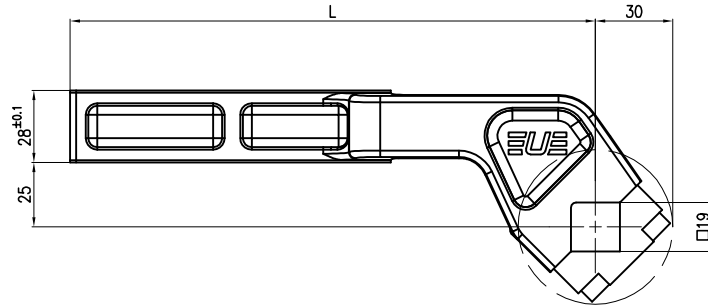

Code	A	B Dowel	C	D Dowel	E	F Dowel	G	J	L	OAL REF	Material
LK019025144WG	90	105	120	135					144	174	Aluminium
LK019025204WG	90	105	120	135	150	165	180	195	204	234	Steel

□22 mm, offset 25 mm for URP/UOP series

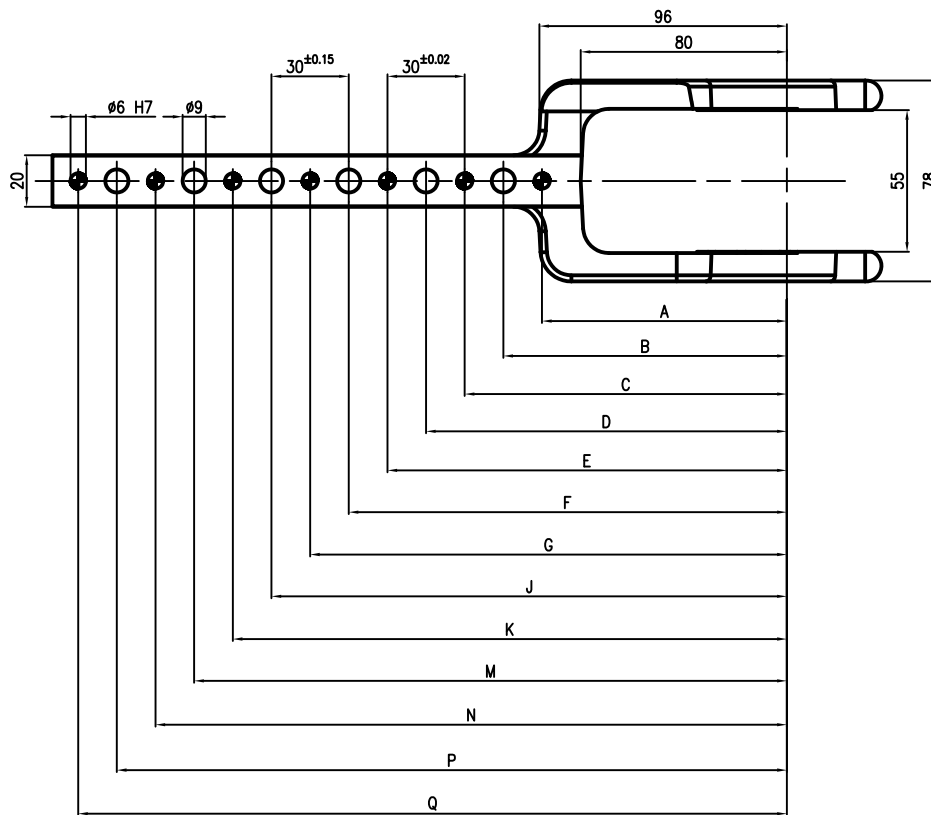
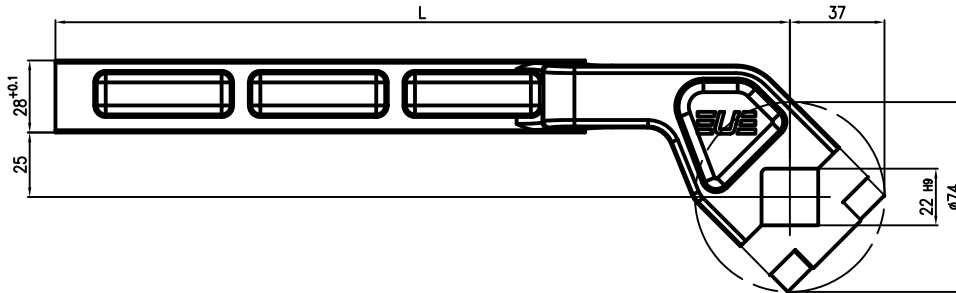

Code	A Dowel	B	C Dowel	D	E Dowel	F	G Dowel	J	K Dowel	M	N Dowel	P	Q Dowel	L	OAL REF	Weight Kg	Material
LKO22025135WN	95	110	125											135	166	0.37	Aluminium
LKO22025165WN	95	110	125	140	155									165	196	0.40	Aluminium
LKO22025195WN	95	110	125	140	155	170	185							195	226	0.43	Aluminium
LKO22025225WN	95	110	125	140	155	170	185	200	215					225	260	1.34	Steel
LKO22025255WN	95	110	125	140	155	170	185	200	215	230	245			255	290	1.42	Steel
LKO22025285WN	95	110	125	140	155	170	185	200	215	230	245	260	275	285	320	1.53	Steel



□22 mm, offset 25 mm

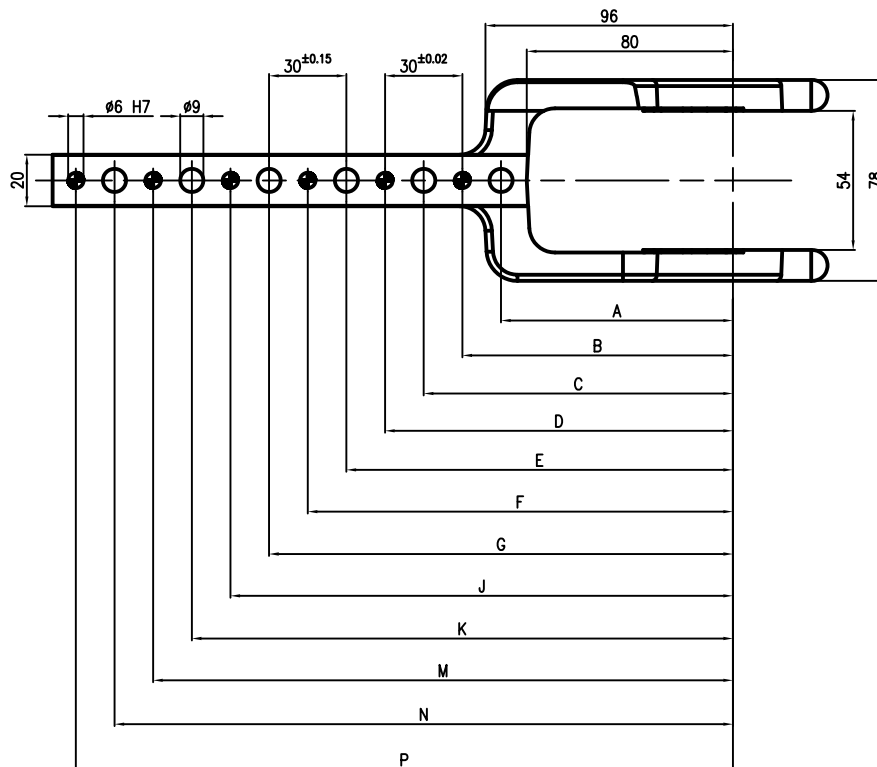
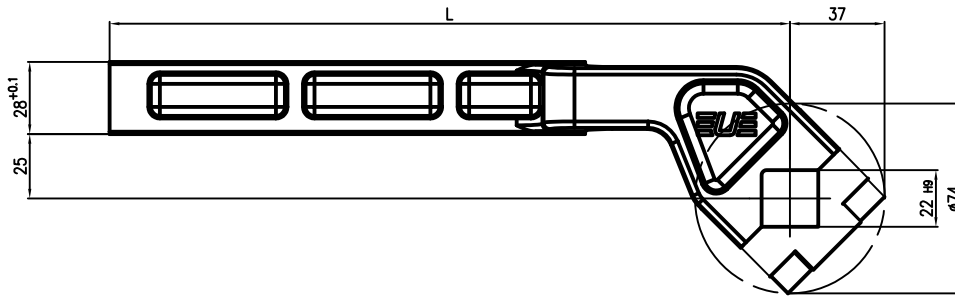

Code	A	B Dowel	C	D Dowel	E	F Dowel	G	J Dowel	K	M Dowel	N	P Dowel	L	OAL REF	Material
LKP22025144WG	90	105	120	135									144	174	Aluminium
LKP22025204WG	90	105	120	135	150	165	180	195					204	234	Steel
LKP22025264WG	90	105	120	135	150	165	180	195	210	225	240	255	264	301	Steel

□22 mm, offset 25 mm for URP/UOP series

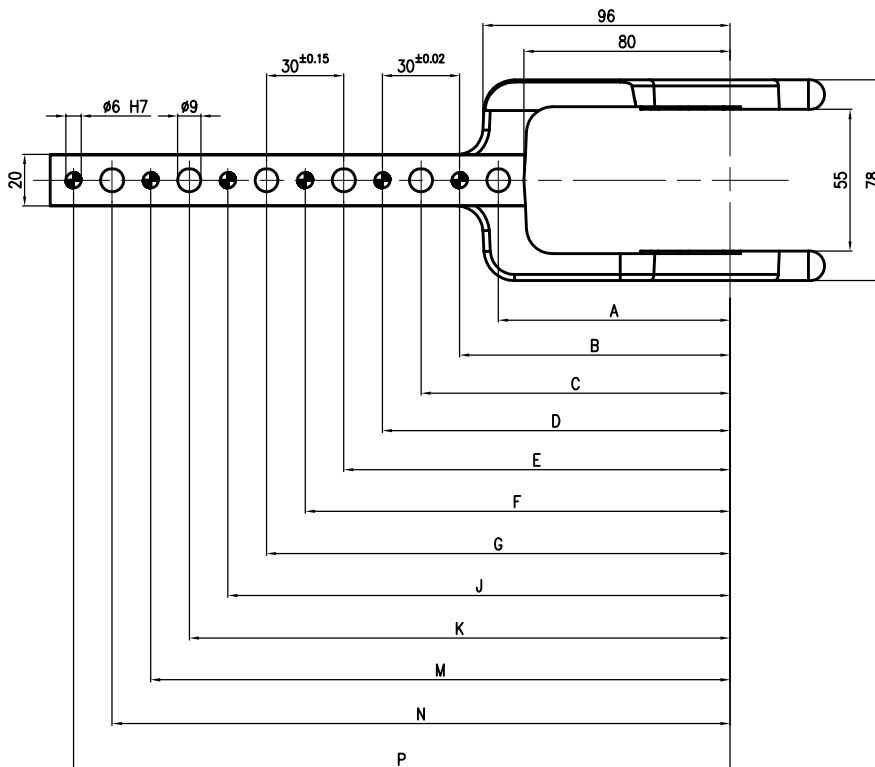
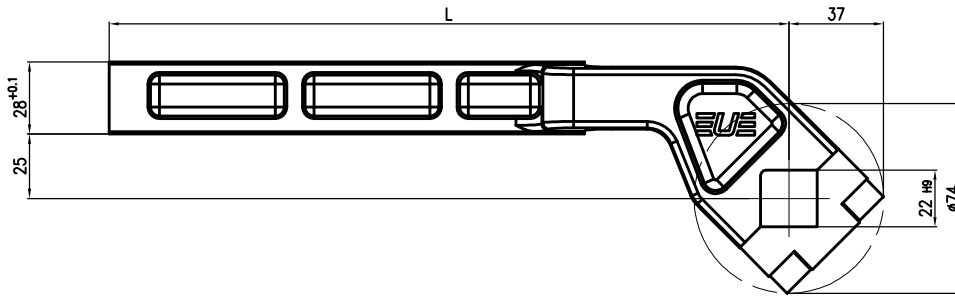

Code	A	B Dowel	C	D Dowel	E	F Dowel	G	J Dowel	K	M Dowel	N	P Dowel	L	OAL REF	Material
LKP22025144WG	90	105	120	135									144	174	Aluminium
LKP22025204WG	90	105	120	135	150	165	180	195					204	234	Steel
LKP22025264WG	90	105	120	135	150	165	180	195	210	225	240	255	264	301	Steel